



**FXTQ
32R**

36W REEFER TRAILER HEAVY DUTY SOLAR TRICKLE CHARGER

MERLIN® TECHNOLOGY

Industry leading power output | Enhanced performance under all light conditions | Designed and engineered in USA | Outstanding aesthetics | Redundancy by design | Robust module integrity and performance under extreme conditions | Military grade design, materials and approvals

SYSTEM OVERVIEW

Maintain 12V starter battery | Charge through optimized charge controller | Operational even on cloudy days | Easy to install, peel & stick flexible panels | Built in diodes in the solar panel to handle shading

CUSTOMER BENEFITS

Trickle charges the reefer battery to accommodate parasitic loads | Prevents battery drainage as units sit unused | Eliminates "lot rot" at dealerships | Minimizes typical battery warranty issues | Reduces jump start requirements | Maintenance free

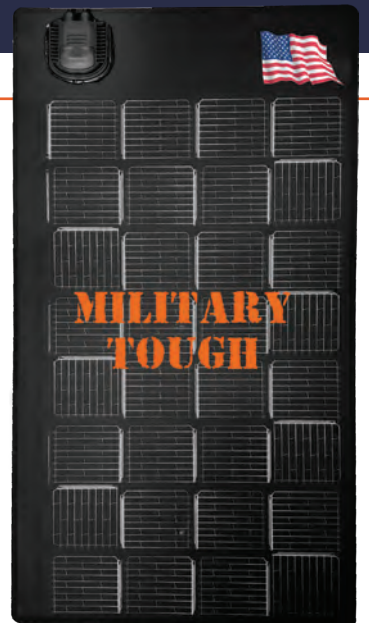

MERLIN® GRID PATENTED TECHNOLOGY: FLEXIBLE – RUGGED – LIGHTWEIGHT – MONO cSi



80% Lighter
than Glass Panels



50X More Durable
vs. Bus-Bar Technology



20% More Energy
In Real World Conditions



2.5X Power Density
vs. Thin Film Technology



36W REEFER TRAILER HEAVY DUTY SOLAR TRICKLE CHARGER

TECHNICAL SPECS

MERLIN® PV Module Specs ¹	Unit	32R
Cell Type Mono		Mono
Number of Cells		32
Rated Power (P Max)	W	36
Voltage at Pmax (Vmp)	V	17.01
Current at Pmax (Imp)	A	2.11
Open Circuit Voltage (Voc)	V	20.46
Short Circuit Current (Isc)	A	2.18
Active Area Efficiency	%	18.4
Temperature Co-efficient of Isc	%/°C	0.05
Temperature Co-efficient of Voc	%/°C	-0.33
Temperature Co-efficient of Pmax	%/°C	-0.42
Operating Temperature	°C	-40 to +85
Charge Controller Key Specs		
IP Configuration		IP68
Charging Set Point	V	14.1V
Operating Temperature	°C	-40 to 60
Dimensions	mm	64 x 51 x 38
	In	2.5 x 2.0 x 1.5

1. STC standard test conditions: 1000W/m² intensity, Air Mass 1.5, 25°C cell temperature. Power Tolerance is +/- 5% W at STC. The electrical characteristics are within +/- 10% unless otherwise specified

2. Specifications are subject to change.

FXTQ-32R

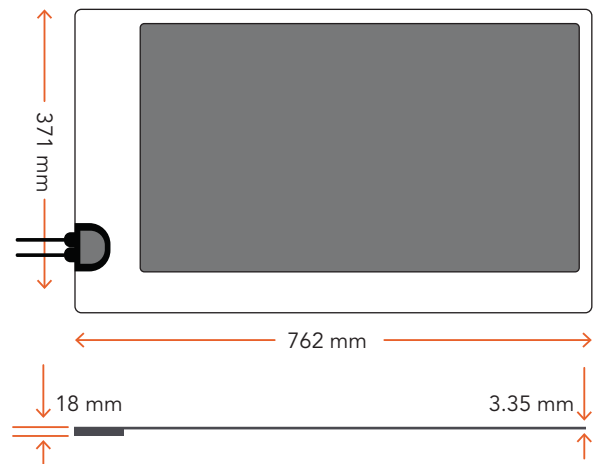

Physical Characteristics				
Units	Length	Width	Thickness*	Weight
mm / kg	762	371	3.35	1.36
in / lb	30	14 ³ / ₈	⁷ / ₁₀	3.0

*Panel at the junction box area 18mm

SCHEMATIC CIRCUIT

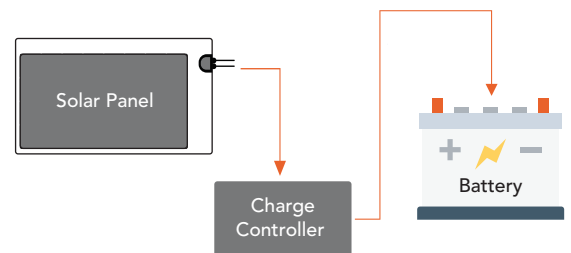

Read more